

HTI

Hydraulic Stud Tensioning Systems

Hydraulic Nut

- Trouble-free, No-Leak, Lo-Friction Seals.
- Overstroke Indicator.
- Extra-Long Working Stroke.
 - Compact and Lightweight Design.
 - Simple to Operate and Maintain.
 - Total Quality Assurance.
 - Dependable Operation.
 - Collar, Shim, or Hydraulic Bolt Styles.

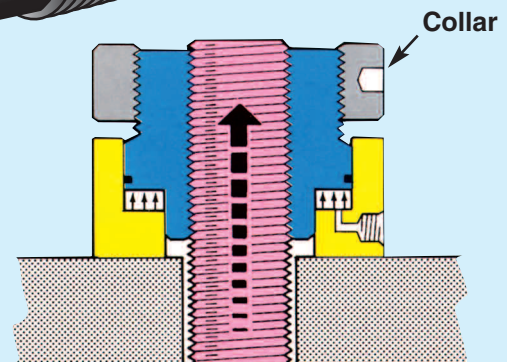
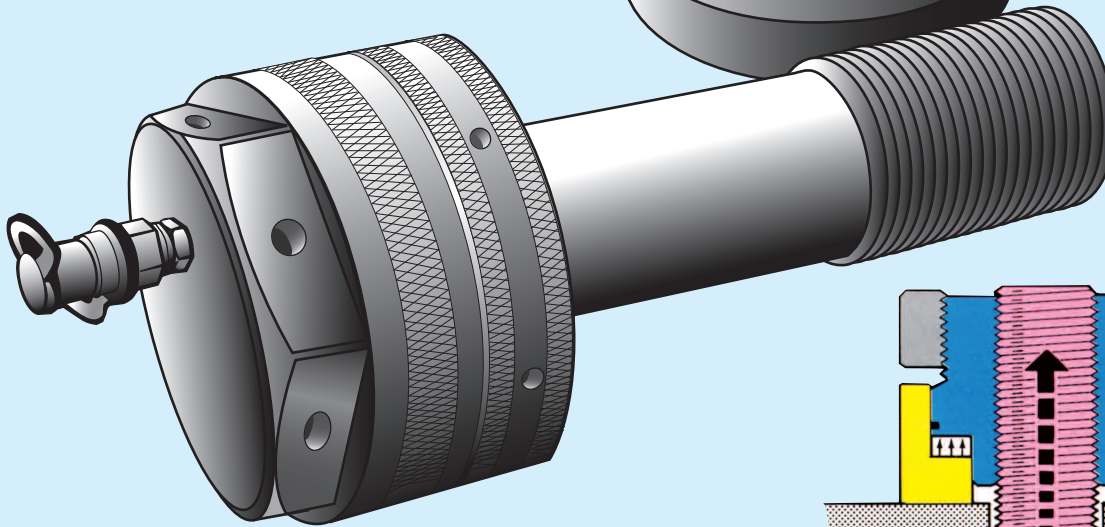
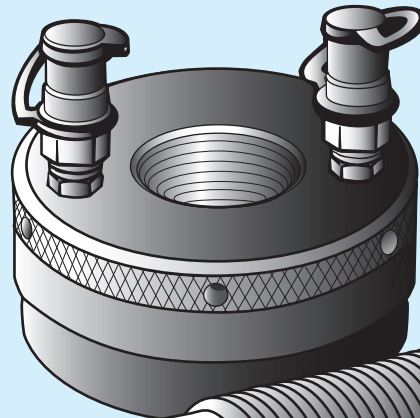
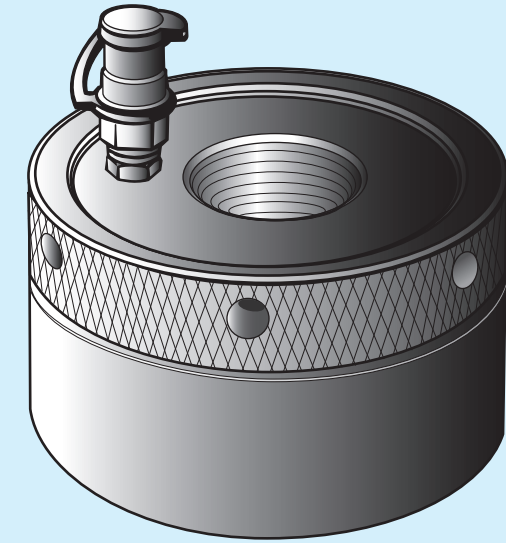

Compact, Easy and Accurate!

The Hydraulic Nut replaces the nut normally used and stays with the stud. This is the most compact system and does not require additional stud length. The operator simply screws the nut down tight and connects the hydraulic hoses. After reaching pressure, he either screws down a collar (style illustrated) or inserts shims designed for the application.

Hydraulic Nut Specifications



Collar Type

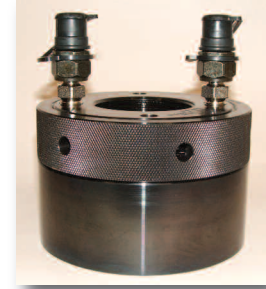
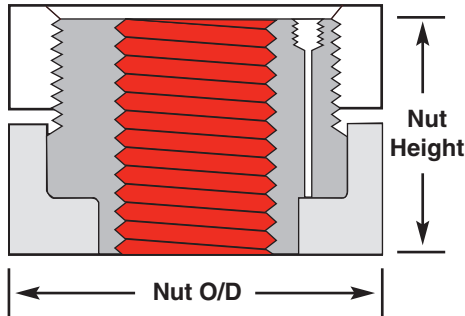

- A minimum of one thread diameter of thread engagement is recommended.
- Stud Load is directly proportional to the pressure applied.
- For top ports allow 9 inches (23 cm) above Tool for Hose and Fitting clearance.
- Side ports are available on Models NG and larger.

Model	Stud Diameter		Maximum Initial Load		Hydraulic Area		Outside Diameter		Overall Height		Maximum Stroke	
	in	mm	lbf	kN	in ²	cm ²	in	mm	in	mm	in	mm
NA	3/4 --- 7/8	M20 - M22	48,060	214	1.66	10.7	2.35	60	2.21	56	0.16	4.1
NB	1 --- 1-1/4	M24 - M33	55,180	245	1.90	12.3	2.64	67	2.29	58	0.16	4.1
NC	1-3/8	M36	69,410	309	2.39	15.4	3.20	81	2.24	57	0.16	4.1
ND	1-1/2 --- 1-5/8	M39 - M42	102,160	454	3.52	22.7	3.50	89	2.31	59	0.16	4.1
NE	1-3/4 --- 1-7/8	M45 - M48	117,120	521	4.04	26.0	4.01	102	2.33	59	0.16	4.1
NF	2	M52	158,980	698	5.41	34.9	4.24	108	2.75	70	0.16	4.1
NG	2-1/4	M56	192,230	855	6.63	42.8	4.67	119	2.90	74	0.16	4.1
NH	2-1/2	M64	238,860	1,063	8.23	53.1	5.23	133	3.34	85	0.20	5.1
NJ	2-3/4 --- 3	M68 - M72	278,020	1,237	9.58	61.8	5.95	151	3.65	93	0.24	6.1
NK	3-1/4	M80	350,280	1,558	12.08	77.9	6.81	173	4.04	103	0.31	7.9
NL	3-1/2	M90	375,910	1,672	12.96	83.6	7.25	184	4.44	113	0.31	7.9
NM	3-3/4	M95	468,460	2,084	16.15	104.2	7.84	199	4.60	117	0.31	7.9
NN	4	M100	539,300	2,399	18.59	119.9	8.43	214	4.83	123	0.39	9.9
NP	4-1/2	M110	615,120	2,736	21.21	136.8	9.00	229	5.30	135	0.39	9.9
NQ	5	M125	660,690	2,939	22.78	146.9	9.60	244	5.78	147	0.39	9.9
NR	5-1/2	M140	774,600	3,446	26.70	172.3	11.05	281	6.41	163	0.59	15.0
NS	6	M150	996,730	4,434	34.36	221.7	11.60	295	6.88	175	0.59	15.0

Maximum Pressure: 29,000 psi • 200 MPa • 2,000 Bars

- Notes:**
1. These specifications are for our standard sizes. Custom designs are our specialty and are readily available.
 2. Total Quality Assurance: We manufacture to strict quality standards. Each major component has a serial number that provides both material and treatment traceability.
 3. Product development is continually taking place and changes to these specifications may occur at any time.

© Copyright Hydraulics Technology Inc. 2009



Hydraulics Technology Inc.

1100 Old Magnolia Road • Conroe, Texas 77304 • (936) 494-2000 • Fax (936) 494-2005
 Website: www.htico.com • E-mail: tensioners@htico.com

